

# COMPACT PRESSURE GAUGE

# PG-75

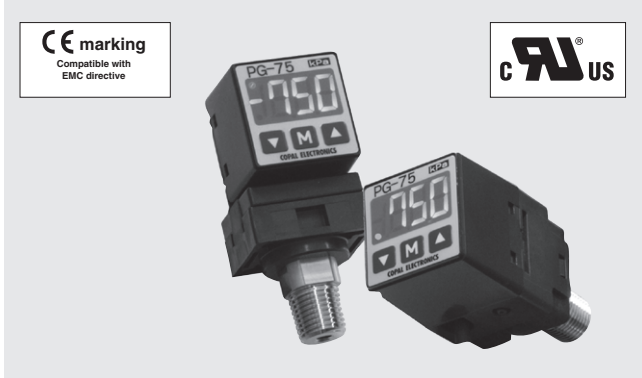

## FEATURES

- Compact, lightweight and multi-functional general-purpose pressure gauge.
- It is adopted welding integral structure with SUS304/316L at pressure receiving section.
- A pressure display function is substantial. (3 1/2digit, 7 segment LED, 2-color LED red / green change, Non-display mode)
- Two types of analog output , one is voltage output (1-5V),The other is current output (4-20mA) .
- The gage pressure is (0 ~ positive pressure), compound pressure range (negative pressure ~ positive pressure),to support maximum of 3.5 MPa.
- Comply with IP65, CE Marking and UL certification obtained.

INTERNAL STRUCTURE (9/16-18UNF)		
Part name		Material
①	Fitting	( Diaphragm SUS316L )
②	Sensor module	
③	Sensor holder	PBT (UL-94-HB)
④	Adapter	
⑤	Housing	Polyester
⑥	Panel sheet	
⑦	Cable	Vinyl chlorid resin (UL2844)

## MODEL NUMBER DESIGNATION

**PG-75-102R-N V R2 B**

Series name

Rated pressure

102G : 0 ~ 100 kPa    102R : -100 ~ 100 kPa  
 103G : 0 ~ 1.0 MPa    103R : -0.1 ~ 1.0 MPa  
 353G : 0 ~ 3.5 MPa    353R : -0.1 ~ 3.5 MPa

Switch output interface

N : NPN open collector  
 P : PNP open collector

Analog output

V : Voltage output (1-5 V)  
 A : Current output (4-20 mA)

Pressure port

Blank : Stem mount  
 B : Back mount

Fitting (With M5 female screw)

R1 : R1/8  
 R2 : R1/4

# PG-75

## COMPACT PRESSURE GAUGE

### LIST OF MODEL NUMBERS

Pressure port	Fitting	SW output	Analog output	Pressure range (Rated range analog output)					
				(0 ~ 100 kPa)	(-100 ~ 100 kPa)	(0 ~ 1.0 MPa)	(-0.1 ~ 1.0 MPa)	(0 ~ 3.5 MPa)	(-0.1 ~ 3.5 MPa)
Stem	R1/8	NPN	1~5V	⇒PG-75-102G-NVR1	⇒PG-75-102R-NVR1	⇒PG-75-103G-NVR1	⇒PG-75-103R-NVR1	⇒PG-75-353G-NVR1	⇒PG-75-353R-NVR1
			4~20mA	⇒PG-75-102G-NAR1	⇒PG-75-102R-NAR1	⇒PG-75-103G-NAR1	⇒PG-75-103R-NAR1	⇒PG-75-353G-NAR1	⇒PG-75-353R-NAR1
		PNP	1~5V	⇒PG-75-102G-PVR1	⇒PG-75-102R-PVR1	⇒PG-75-103G-PVR1	⇒PG-75-103R-PVR1	⇒PG-75-353G-PVR1	⇒PG-75-353R-PVR1
			4~20mA	⇒PG-75-102G-PAR1	⇒PG-75-102R-PAR1	⇒PG-75-103G-PAR1	⇒PG-75-103R-PAR1	⇒PG-75-353G-PAR1	⇒PG-75-353R-PAR1
	R1/4	NPN	1~5V	⇒PG-75-102G-NVR2	⇒PG-75-102R-NVR2	⇒PG-75-103G-NVR2	⇒PG-75-103R-NVR2	⇒PG-75-353G-NVR2	⇒PG-75-353R-NVR2
			4~20mA	⇒PG-75-102G-NAR2	⇒PG-75-102R-NAR2	⇒PG-75-103G-NAR2	⇒PG-75-103R-NAR2	⇒PG-75-353G-NAR2	⇒PG-75-353R-NAR2
Back	R1/8	NPN	1~5V	⇒PG-75-102G-NVR1B	⇒PG-75-102R-NVR1B	⇒PG-75-103G-NVR1B	⇒PG-75-103R-NVR1B	⇒PG-75-353G-NVR1B	⇒PG-75-353R-NVR1B
			4~20mA	⇒PG-75-102G-NAR1B	⇒PG-75-102R-NAR1B	⇒PG-75-103G-NAR1B	⇒PG-75-103R-NAR1B	⇒PG-75-353G-NAR1B	⇒PG-75-353R-NAR1B
		PNP	1~5V	⇒PG-75-102G-PVR1B	⇒PG-75-102R-PVR1B	⇒PG-75-103G-PVR1B	⇒PG-75-103R-PVR1B	⇒PG-75-353G-PVR1B	⇒PG-75-353R-PVR1B
			4~20mA	⇒PG-75-102G-PAR1B	⇒PG-75-102R-PAR1B	⇒PG-75-103G-PAR1B	⇒PG-75-103R-PAR1B	⇒PG-75-353G-PAR1B	⇒PG-75-353R-PAR1B
	R1/4	NPN	1~5V	⇒PG-75-102G-NVR2B	⇒PG-75-102R-NVR2B	⇒PG-75-103G-NVR2B	⇒PG-75-103R-NVR2B	⇒PG-75-353G-NVR2B	⇒PG-75-353R-NVR2B
			4~20mA	⇒PG-75-102G-NAR2B	⇒PG-75-102R-NAR2B	⇒PG-75-103G-NAR2B	⇒PG-75-103R-NAR2B	⇒PG-75-353G-NAR2B	⇒PG-75-353R-NAR2B
		PNP	1~5V	⇒PG-75-102G-PVR2B	⇒PG-75-102R-PVR2B	⇒PG-75-103G-PVR2B	⇒PG-75-103R-PVR2B	⇒PG-75-353G-PVR2B	⇒PG-75-353R-PVR2B
			4~20mA	⇒PG-75-102G-PAR2B	⇒PG-75-102R-PAR2B	⇒PG-75-103G-PAR2B	⇒PG-75-103R-PAR2B	⇒PG-75-353G-PAR2B	⇒PG-75-353R-PAR2B

⇒ The products marked ⇒ are manufactured upon receipt of order basis.

### STANDARD SPECIFICATIONS

Model number	PG-75						
	102G	103G	353G	102R	103R	353R	
Pressure reference	Gauge			Gauge (Compound)			
Rated pressure	Pr(L) ~ Pr(H)	0 ~ 100 kPa	0 ~ 1.0 MPa	0 ~ 3.5 MPa	-100 ~ 100 kPa	-0.1 ~ 1.0 MPa	-0.1 ~ 3.5 MPa
Maximum pressure	Pmax	200 kPa	2 MPa	5 MPa	200 kPa	2 MPa	5 MPa
Break-down pressure	Pb	300 kPa	3 MPa	7 MPa	300 kPa	3 MPa	7 MPa
Full-scale	FS	100 KPa	1 MPa	3.5 MPa	200 kPa	1.1 MPa	3.6 MPa
Pressure Medium	Corrosive gases/Liquids compatible with SUS304 and SUS316L						
Sealed liquid	Silicone oil						
Operating voltage	Vopr	10.8 ~ 30 VDC (Including ripple percentage)					
Consumption current	50 mA maximum (Not included current analog output)						
Protection grade	IP65 of IEC						
Operating temp.	-10 ~ 50 °C (Storage Temperature : -20 ~ 70 °C )						
Operating humidity	35 ~ 85 %RH						
Insulation resistance	100 MΩ minimum at 500 VDC between bundled leads and pressure port						
Dielectric strength	One minuts at 500 VAC between bundled leads and pressure port (1mA maximum leakage)						
Pressure Port	R1 (R1/8) , R2 (R1/4)						
Type of mounting	Stem mount, Back mount						
Fitting materials	Diaphragm : SUS316L, Fitting : SUS304						
Net Weight	Approx. 115±15 g (incl. 2 m cable)						

# PG-75

## COMPACT PRESSURE GAUGE

### STANDARD SPECIFICATIONS

	Model number	PG-75					
		102G	103G	353G	102R	103R	353R
Switch output	Number of outputs	Two outputs (NPN/PNP)					
	Switching capacity	30 VDC / 100 mA maximum					
	Residual voltage	1.2 V maximum (NPN) / 2.2 V maximum (PNP), Load current 100 mA					
	Hysteresis	0 ~ Approx 0.3Pr(H),(Adjustable)					
	Repeatability	±0.3 %F.S. / Reference temp. 25 °C					
	Accuracy	±2%F.S. (Integrated accuracy:Including errors of setting, linearity, hystresis and thermal error.)					
	Response	Approx 5 ms (Digital filter settings : "F0")					
	Protection	Exists / Short circuit protection(Switch Overload current detection :Approx 150 mA minimum)					
	State indication	SW monitor LED(2 points) ,Lighted when the switch output is ON.(Pressure display inverted colors)					
	Analog output	Voltage output					
Vo		1 ~ 5V / Pr(L) ~ Pr(H) , F.S. : 4 V					
Accuracy		±2%F.S. (Integrated accuracy) /Measurement load resistance(1 MΩ maximum)					
Resolution		Approx 2.7 mV (Approx. 0.068% F.S).(11bit DAC)					
Output resistance		Approx. 1 kΩ(Internal impedance)					
Response		Approx. 2 ms maximum					
Current output							
Io		4 ~ 20 mA / Pr(L) ~ Pr(H), F.S. : 16 mA					
Accuracy		±2%F.S. (Integrated accuracy) /Measurement load resistance(250 Ωmaximum)					
Resolution		Approx. 0.011mA (Approx 0.068% F.S.) (11bit DAC)					
Output resistance		Vopr ≤ 18 VDC : 50 ~ 300 Ω, Vopr > 18 VDC : 50 ~ 500 Ω					
Response		Approx. 2 ms maximum					
Pressure display		Display element	3 1/2 digits, 7 segment LED (Red/Green) Reverse display selectable in tandem with SW1.				
	Display cycle	5 times /sec (moving average)					
	Accuracy	±2% F.S. (Integrated accuracy)					

### ENVIRONMENTAL CHARACTERISTICS

Test item	Test conditions (At 25 ± 5 °C)	Permissible change
Vibration	10 ~ 500 Hz 1.5 mm maximum / 98.1 m/s <sup>2</sup> , three directions, two hours each	Pressure indication, switch operating pressure and analog output (zero and span) : ± 2%F.S. maximum during test
Shock	490 m/s <sup>2</sup> , three directions, three times each	
Pressure cycling	0~Rated pressure, 10 <sup>6</sup> cycles	
Moisture resistance	40 °C, 90~95 %RH, 240 hrs.	

# PG-75

## COMPACT PRESSURE GAUGE

### ENVIRONMENTAL CHARACTERISTICS

Test item	Test conditions (At 25 ± 5 °C)	Permissible change
EMC	EMI : EN55011: 2009, A1: 2010 Group 1, class B EMS : EN61326-1 : 2006 Table 2 EN61326-2-3 : 2006 Annex BB	Pressure indication, switch operating pressure and analog output : ± 5 %F.S. maximum during test

### MULTIPLIER FACTOR

The multiplier factor is selectable by changing the value of third digit on the display during the operation setting.

Code/Multiplier Factor	Pressure Range / Display specification rated pressure					
	102G	102R	103G	103R	353G	353R
1: ×1 (kPa)	0.0 ~ 100.0	-100.0 ~ 100.0	0 ~ 1000	-100 ~ 1000	—	—
2: ×0.0102	.000 ~ 1.020	-1.020 ~ 1.020	0.00 ~ 10.20	-1.02 ~ 10.20	0.0 ~ 35.7	-1.0 ~ 35.7
3: ×10.2	0 ~ 1020	-1020 ~ 1020	—	—	—	—
4: ×7.501	0 ~ 750	-750 ~ 750	—	—	—	—
5: ×0.01	.000 ~ 1.000	-1.000 ~ 1.000	0.00 ~ 10.00	-1.00 ~ 10.00	0.0 ~ 35.0	-1.0 ~ 35.0
6: ×10	0 ~ 1000	-1000 ~ 1000	—	—	—	—
7: ×0.145	0.0 ~ 14.5	-14.5 ~ 14.5	0.0 ~ 145.0	-14.5 ~ 145.0	0 ~ 508	-15 ~ 508
8: ×0.001 (MPa)	—	—	.000 ~ 1.000	-1.00 ~ 1.000	0.00 ~ 3.50	-0.10 ~ 3.50
9: ×0.2953	0.0 ~ 29.5	-29.5 ~ 29.5	0 ~ 295	-30 ~ 295	0 ~ 1033	-30 ~ 1033

- The settings indicated by "-" on the table above are not selectable because of resolution.
- Either "1"(for 102A, 102V, 102G, and 102R) or "8" (for 103G, 103R, 353G and 353R) are set prior to delivery.
- Changes of the multiplier factor apply to display values. Also, note the changes reset switch setting value and hysteresis.

### SWITCH OUTPUT MODE

SW output is selectable by changing the value of first digit on the display.

<SW Operation Code>

Output	SW1				SW2			
	Separate		Window comparator		Separate		Window comparator	
Mode	HI	LO	A	B	HI	LO	A	B
Operation 1	○				○			
Operation 2	○					○		
Operation 3		○				○		
Operation 4		○				○		
Operation 5			○				○	
Operation 6			○				○	
Operation 7				○				○
Operation 8				○				○
Pressure setting (Operating point)	Set 1		(Minimum) Set 1 (Maximum) Set 3		Set 2		(Minimum) Set 1 (Maximum) Set 4	

<Switch Operation Mode>

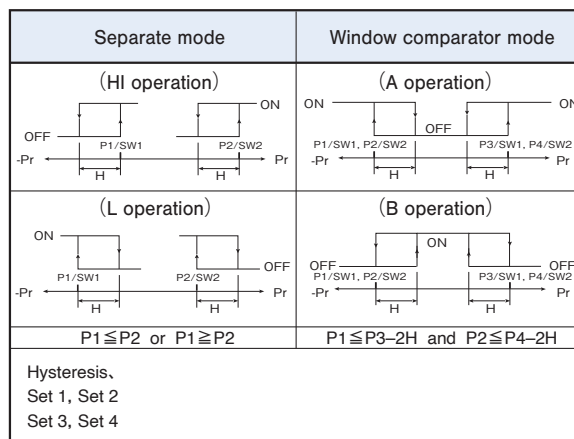

- In the Separate mode, SW 1 corresponds to Setting 1 and SW2 corresponds to Setting 2.
- In the Window Comparator Mode, SW 1 corresponds to the Setting 1 (lower limit) and Setting 3 (upper limit). Also, SW2 corresponds to the setting (lower limit) and setting 4 (upper limit).
- The Hysteresis (H) setting is common to SW 1 and SW 2 operations.
- When SW operation is changed between the Separate Mode and Window Comparator Mode, SW pressure settings that are set separately will be reset.

# PG-75 COMPACT PRESSURE GAUGE

## EXTERNALS SPECIFICATION (unit:mm)

### Vertical installation type

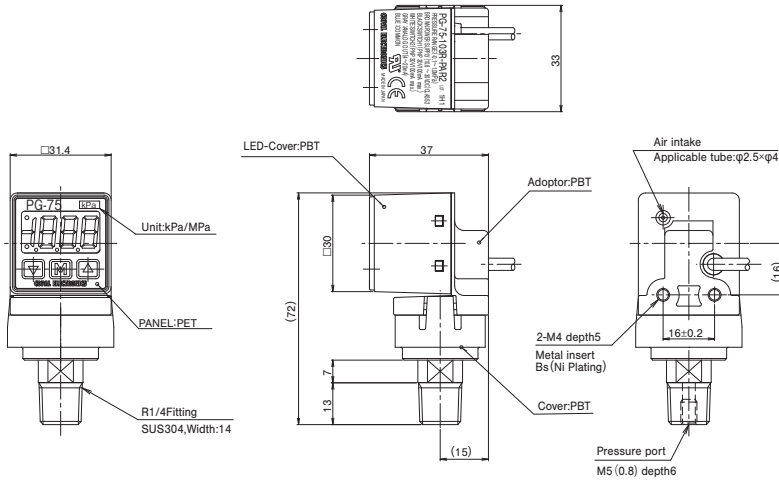

### The horizontal installation type

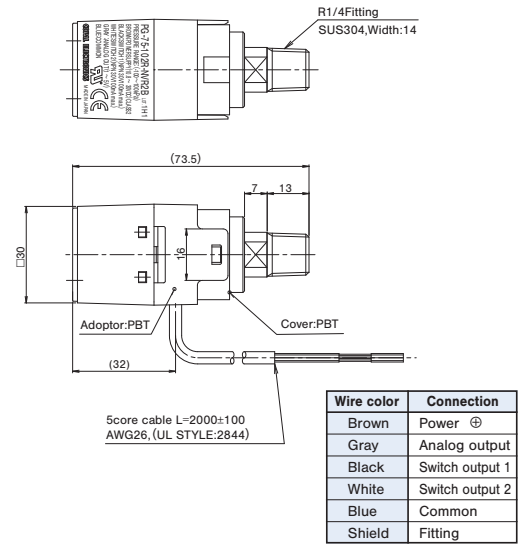

## MEANS OF ATTACHMENT (Option)

### Vertical installation type

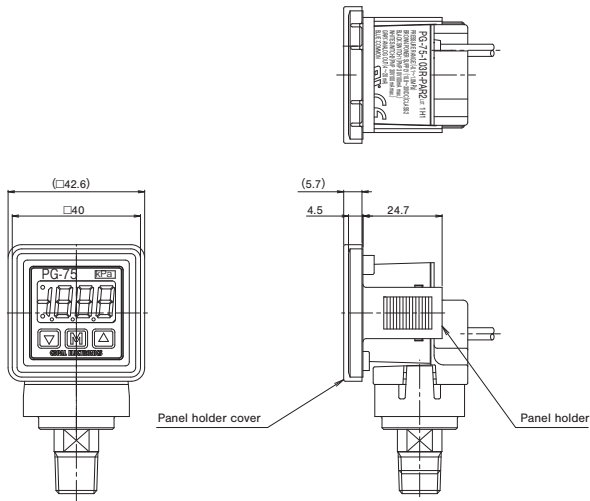

### The horizontal installation type

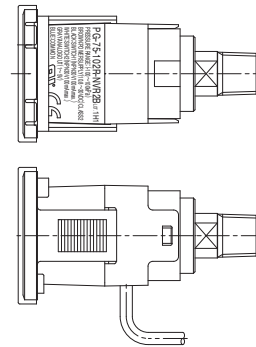

## INTERNAL ELECTRICAL SCHEMATICS

### NV/NA:NPN

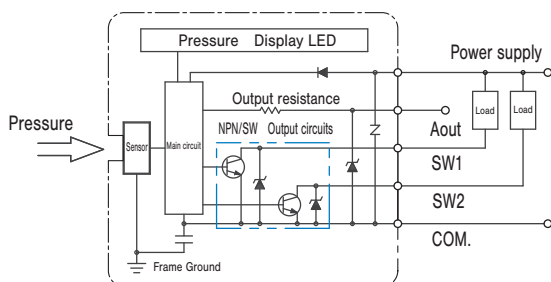

### PV/PA:PNP

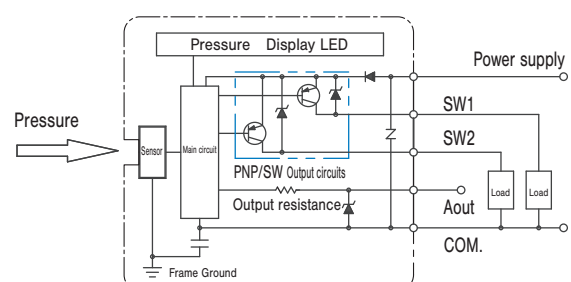

# PG-75

## COMPACT PRESSURE GAUGE

### Others

#### ● Tube at air intake

If there is a possibility that liquids such as water, oil etc splash to the main body and it may flow into the inside of the product through the air intake, connect a silicon tube to the air intake and position the other end of the tube in a suitable safe place. At that time, do not bend the tube or block the other end of the tube.

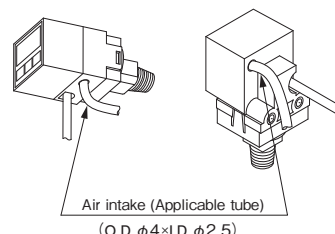

#### ● Piping

Use a wrench on the hexagon of the fitting. Do not hold the main body when tightening.

### ACCESSORIES (Sold separately)

Name	Series name	Contents	Applicable model
Panel holder set	ACPG-003	Panel holder cover Panel holder Panel stopper (2pcs.)	PG-30 · PG-35 · PG-75 PG-35H · PG-35L · PS30
Holder cover set (For protecting gauge operating panel)	ACPG-004	Panel holder cover Panel holder	PG-30 · PG-35 · PG-75 PG-35H · PG-35L · PS30
holder stopper set	ACPG-007	Panel holder Panel stopper (2pcs.)	PG-30 · PG-35 · PG-75 PG-35H · PG-35L · PS30

### HOW TO MOUNT OPTIONAL ACCESSORIES (Sold separately)

(Unit: mm)

#### ● PG-30 · PG-35 · PG-35H · PG-35L · PG-75 · PS30 Panel cut holder set & holder cover set

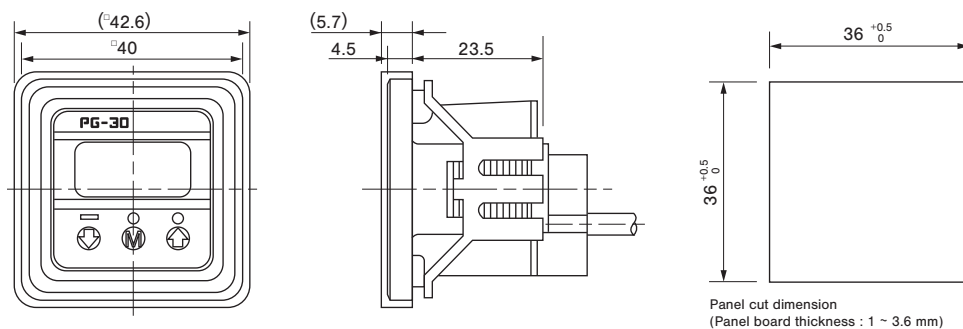

#### ● Panel holder cover set

