

REVISIONS					
P	LTR	DESCRIPTION	DATE	DMN	APVD
AK2		REVISED PER ECO-13-005696	25JUL13	KH	MM
AL		REVISED PER ECO-17-014152	12JAN2018	RS	MM

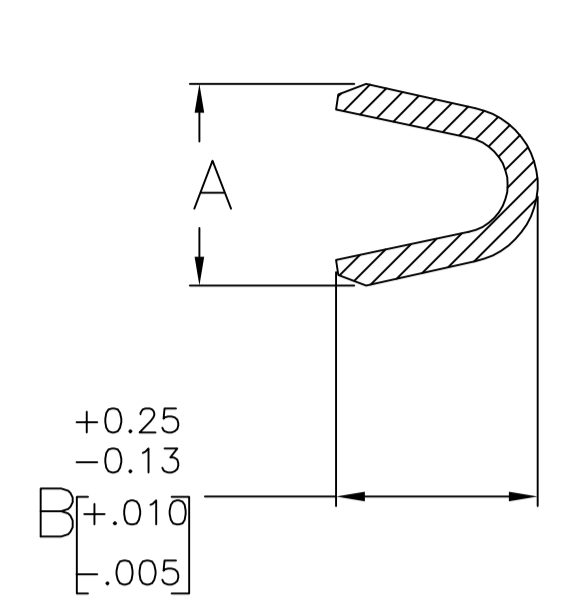

SECTION H-H

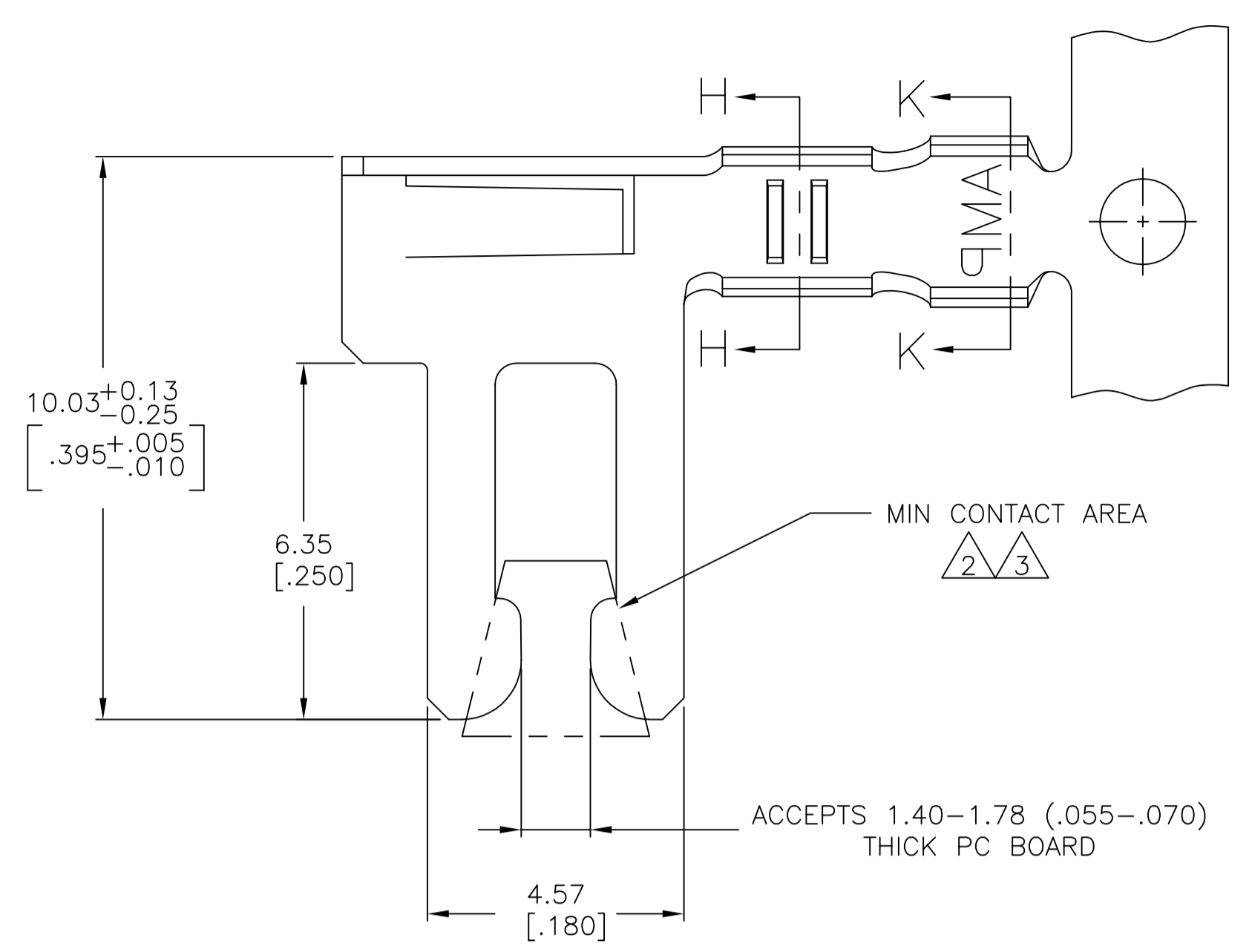
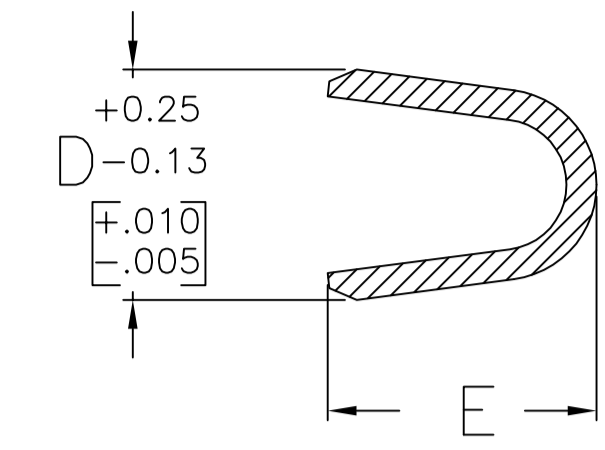

SECTION K-K

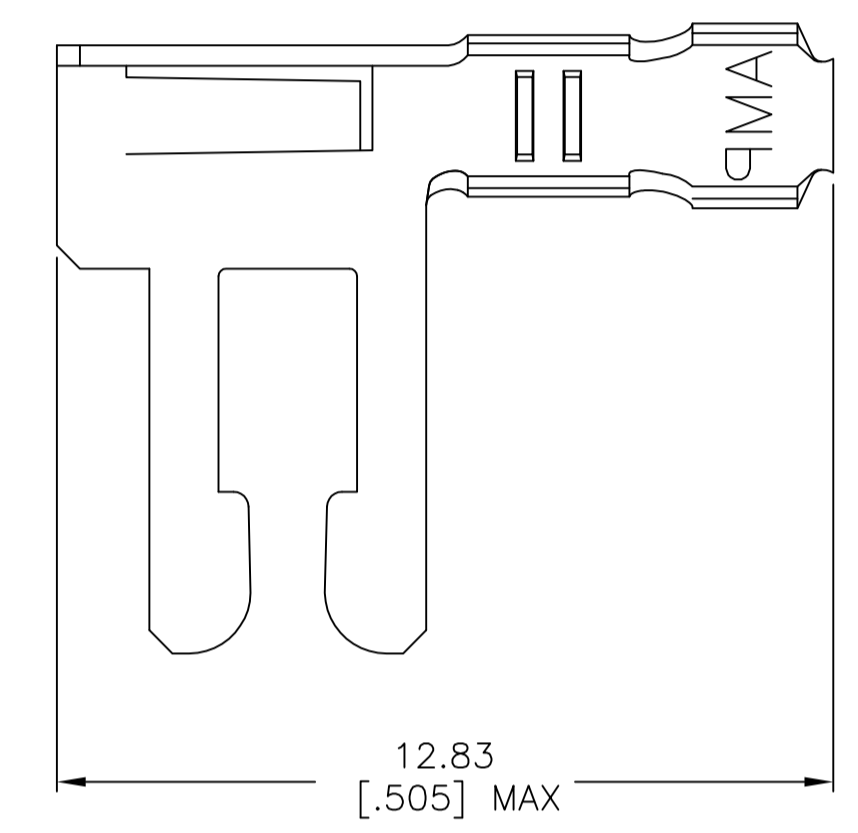

DETAIL X
SCALE 8:1

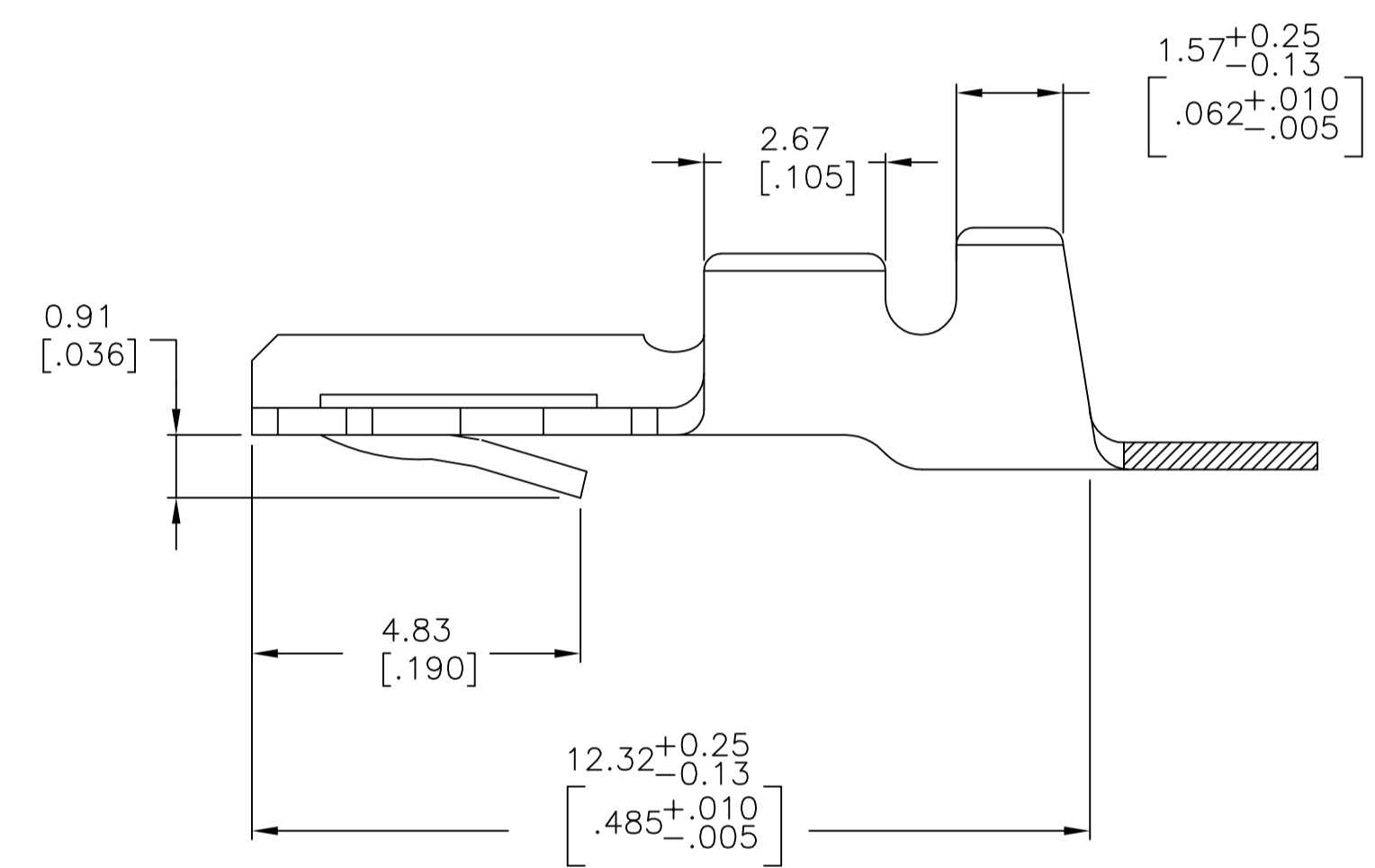

- 1 REFER TO CUSTOMER DRAWINGS 530509, 530853, 582370, & 582380 FOR HOUSING AND PC BOARD REQUIREMENTS.
- 2 0.76 μ m[.000030] MIN GOLD OVER 1.27 μ m[.000050] MIN NICKEL IN CONTACT AREA, 1.27 μ m[.000050] MIN NICKEL ON REMAINDER OF CONTACT.
- 3 0.38 μ m[.000030] MIN GOLD OVER 1.27 μ m[.000050] MIN NICKEL IN CONTACT AREA, 1.27 μ m[.000050] MIN NICKEL ON REMAINDER OF CONTACT.
- 4 3.81 μ m[.000150] MIN TIN-LEAD OVER 0.76 μ m[.000030] MIN NICKEL ALL OVER.
- 5 FOR USE WITH STANDARD APPLICATOR.
- 6 FOR USE WITH MINATURE APPLICATOR.
- 7 3.81 μ m[.000150] MIN MATTE TIN PLATE OVER 0.76 μ m[.000030] MIN NICKEL ALL OVER.
- 8 OBSOLETE PARTS: OBSOLETE CIS STREAMLINING PER D.RENAUD/D.SINISI

8	OBSOLETE	0.89-1.40 [.035-.055]	26-22	2.16 [.085]	2.54 [.100]	1.90 [.075]	1.90-2.41 [.075-.095]	PER DETAIL-X	-	4	5-66150-2
8	OBSOLETE	1.52-2.29 [.060-.090]	22-18	3.56 ^{+0.25} _{-0.13} [.140 ^{+0.010} _{-.005}]	3.05 [.120]	2.67 [.105]	2.67-3.30 [.105-.130]	PER DETAIL-X	-	4	5-66088-2
		0.89-1.40 [.035-.055]	26-22	2.16 [.085]	2.54 [.100]	1.90 [.075]	1.90-2.41 [.075-.095]	-	6	4	5-66362-1
		1.52-2.29 [.060-.090]	22-18	3.56 ^{+0.25} _{-0.13} [.140 ^{+0.010} _{-.005}]	3.05 [.120]	2.67 [.105]	2.67-3.30 [.105-.130]	-	6	4	5-66335-2
8	OBSOLETE	1.52-2.29 [.060-.090]	22-18	3.56 ^{+0.25} _{-0.13} [.140 ^{+0.010} _{-.005}]	3.05 [.120]	2.67 [.105]	2.67-3.30 [.105-.130]	-	5	4	5-60215-4
	OBSOLETE	0.89-1.40 [.035-.055]	26-22	2.16 [.085]	2.54 [.100]	1.90 [.075]	1.90-2.41 [.075-.095]	PER DETAIL-X	-	4	66150-2
		1.52-2.29 [.060-.090]	22-18	3.56 ^{+0.25} _{-0.13} [.140 ^{+0.010} _{-.005}]	3.05 [.120]	2.67 [.105]	2.67-3.30 [.105-.130]	PER DETAIL-X	-	4	66088-2
	OBSOLETE	0.89-1.40 [.035-.055]	26-22	2.16 [.085]	2.54 [.100]	1.90 [.075]	1.90-2.41 [.075-.095]	-	6	4	66362-2
		0.89-1.40 [.035-.055]	26-22	2.16 [.085]	2.54 [.100]	1.90 [.075]	1.90-2.41 [.075-.095]	-	6	4	66362-1
8	OBSOLETE	1.52-2.29 [.060-.090]	22-18	3.56 ^{+0.25} _{-0.13} [.140 ^{+0.010} _{-.005}]	3.05 [.120]	2.67 [.105]	2.67-3.30 [.105-.130]	-	6	4	66335-3
		1.52-2.29 [.060-.090]	22-18	3.56 ^{+0.25} _{-0.13} [.140 ^{+0.010} _{-.005}]	3.05 [.120]	2.67 [.105]	2.67-3.30 [.105-.130]	-	6	4	66335-2
		1.52-2.29 [.060-.090]	22-18	3.56 ^{+0.25} _{-0.13} [.140 ^{+0.010} _{-.005}]	3.05 [.120]	2.67 [.105]	2.67-3.30 [.105-.130]	-	5	4	60215-5
		1.52-2.29 [.060-.090]	22-18	3.56 ^{+0.25} _{-0.13} [.140 ^{+0.010} _{-.005}]	3.05 [.120]	2.67 [.105]	2.67-3.30 [.105-.130]	-	5	4	60215-4
		INSULATION DIA RANGE	WIRE GAGE RANGE	E	D	B	A	LOOSE PIECE	REELING	FINISH	PART NUMBER

THIS DRAWING IS A CONTROLLED DOCUMENT. DMN M. BINNER 09 JUL 97
CHK R. STONE 11 NOV 97

DIMENSIONS: mm [INCHES] TOLERANCES UNLESS OTHERWISE SPECIFIED:

0 PLC	±	-
1 PLC	±	-
2 PLC	±	0.13 [0.005]
3 PLC	±	0.13 [0.005]
4 PLC	±	-
ANGLES	±	-

MATERIAL: PHOSPHOR BRONZE FINISH: SEE TABLE

APVD: D. WIKE 09 APR 98 NAME: D. WIKE

PRODUCT SPEC: 108-9016

APPLICATION SPEC: 114-9002

WEIGHT: A1 00779

SCALE: 10:1 SHEET: 1 OF 1

RESTRICTED TO: CUSTOMER DRAWING

STE TE Connectivity

CONTACT, DUO-TYNE™ FLAG

SIZE: A1 CAGE CODE: 00779 DRAWING NO: 60215