

ISS.	AMEND	DATE
1	ISSUED	17/06/22

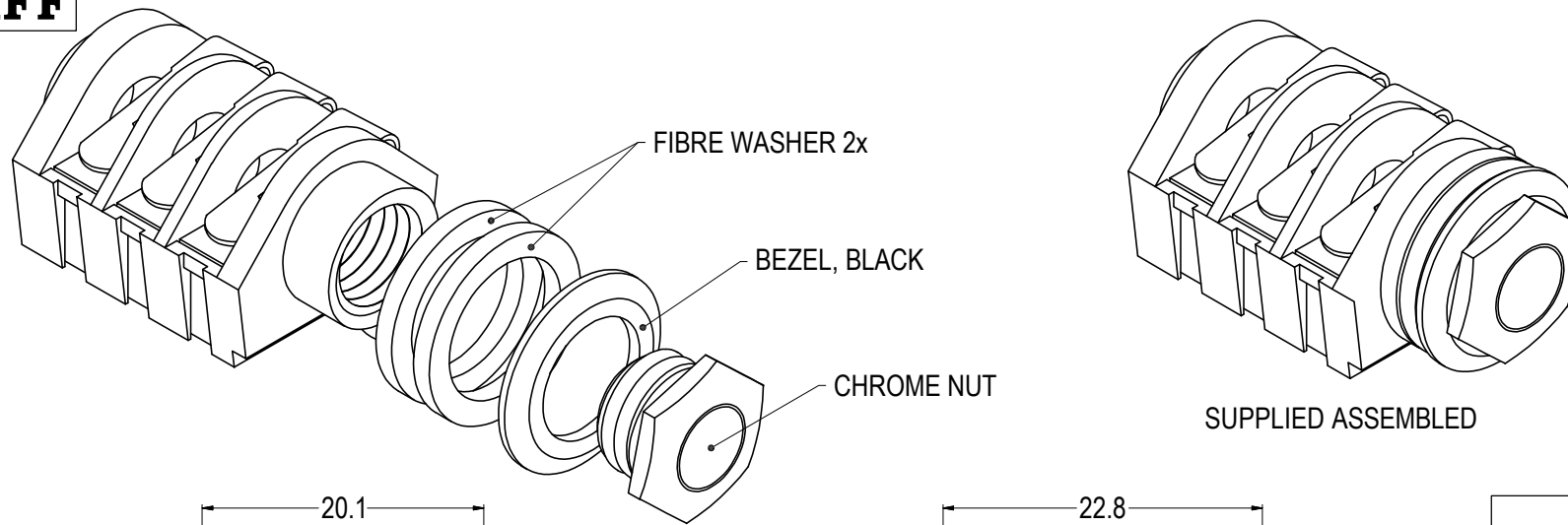

SUPPLIED ASSEMBLED

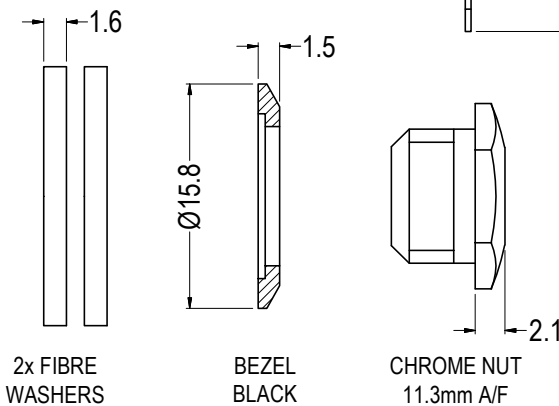
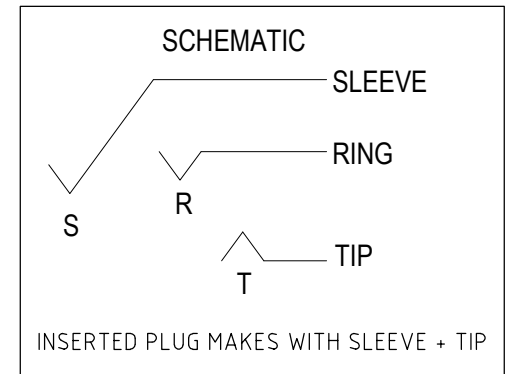
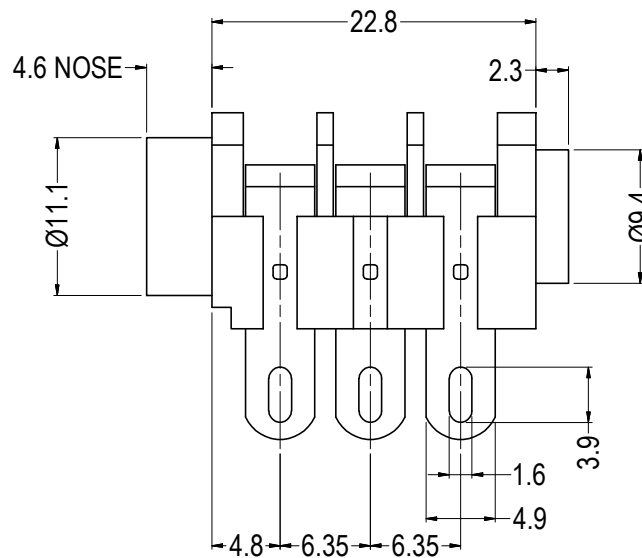
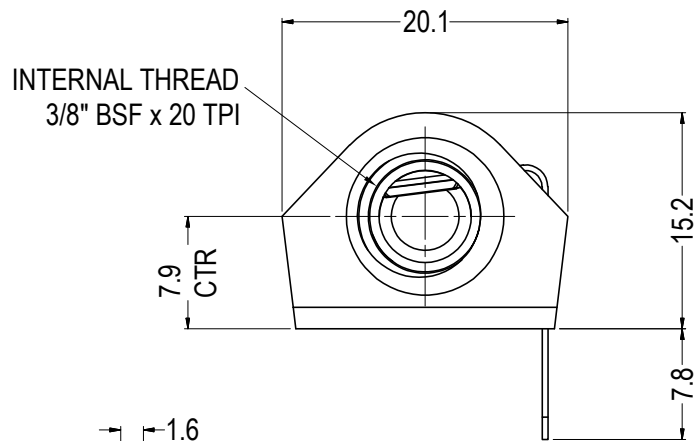

**SPECIFICATION**

Withstand voltage: 2000V DC Min.  
 Maximum Current: 5A  
 Temperature Rating: -10° C to +70° C  
 Life (Minimum): 10,000+ Operations  
 Nominal Contact Resistance: <50mΩ  
 Max Panel Thickness: 4.3mm

**RoHS**  
**COMPLIANT**

**TOLERANCE**  
 NO DEC. PLACE ±  
 1 DEC. PLACE ±  
 2 DEC. PLACE ±  
 HOLE Ø ±  
 ANGLES ±  
 UNLESS OTHERWISE STATED

**Cliff Electronic Components Ltd.**

76 Holmethorpe Avenue, Holmethorpe Industrial Estate,  
 Redhill, Surrey, RH1 2PF, England, UK  
 Tel: 01737-771375 Fax: 01737-766012 Website: www.cliffuk.co.uk

DIMENSIONS IN MILLIMETERS UNLESS OTHERWISE STATED. WORK TO DIMENSIONS. REMOVE ALL BURRS. IF IN DOUBT ASK.

3rd ANGLE PROJECTION:

DO NOT SCALE

MATERIAL: NYLON / NiAg / FIBRE / POM / BRASS

TITLE: JACK SOCKET S4/SSS ASSEMBLED

FINISH: AS MOULDED / MICROFINISH

THE CONTENTS OF THIS DOCUMENT MUST NOT BE COPIED OR DISCLOSED TO A 3rd PARTY WITHOUT WRITTEN PERMISSION OF CLIFF UK. © 2022

DRAWN: T.J.O.

APPROVED: D.P.J.

DRWG. No. **CL1320A**

FORM: A4DRWGH