



# Part No. 1002427

## ISM or ISM & BT or GPS Stamp Metal Embedded SMT Antenna

868 MHz, 915 MHz, 1.575 GHz, 2.4 GHz

Supports: Wi-Fi applications, Agriculture, Automotive, Bluetooth, Tracking, Smart Home, Healthcare, Digital Signage



### ISM or ISM & BT or GPS Stamp Metal Embedded Antenna

868-915 MHz, 1.575-1.606 GHz, 2.4 GHz

#### KEY BENEFITS

##### Versatile Antenna

1002427 can be used to support ISM or GPS independently or ISM and BT combined, allowing reduced BOM complexity while maintaining great performances.

##### Quicker Time-to-Market

By optimizing antenna size, performance and emissions, customer and regulatory specifications are more easily met.

##### Reliability

Products are the latest RoHS version compliant.

#### APPLICATIONS

- Embedded design
- Cellular, Headsets, Tablets
- Gateway, Access Point
- Handheld
- Telematics
- Tracking
- Healthcare
- M2M, Industrial devices
- Smart Grid
- OBD-II

KYOCERA AVX 1002427 stamp metal SMT antenna delivers the device designers' key needs for higher functionality and performance in smaller/thinner designs. This innovative antenna provides compelling advantages for all ISM, Bluetooth and GPS enabled devices.

#### Unique Form Factors Support Advanced Industrial Designs

Smaller, more efficient on board embedded antennas break through restrictive design rules and provide new freedom in component placement. 1002427 offers 3 configurations for tuning, ISM layout, ISM and BT layout or GPS layout.

#### Electrical Specifications

Typical performance on 110 x 55 mm PCB in free space. Different antenna layout location per each frequency configuration tested.

Frequency	ISM Layout 868-915 MHz	ISM & BT Layout 915 / 2450 MHz		GPS Layout 1560—1606 MHz
Peak Gain	1.0 dBi	3.0 dBi	3.4 dBi	1.8 dBi
Average Efficiency	62%	67%	61%	65%
VSWR Match	2.0:1 max			
Feed Point Impedance	50 ohms unbalanced			
Polarization	Linear			
Power Handling	2 Watt CW			

#### Mechanical Specifications & Ordering Part Number

Ordering Part Number	1002427
Size (mm)	31.2 x 2.28 x 3.9
Weight (grams)	0.16
Mounting	SMT, Through-Hole, (P&P)
Packaging	Tape & Reel, 5,400 pieces per box, 1,800 per reel
Demo Board	1002427-01

ISM / GPS / BT Stamp Metal KYOCERA AVX Antenna Specifications  
 KYOCERA AVX produces a wide variety of standard and custom antennas to meet user needs.

**Antenna Dimensions (1002427)**

Typical antenna dimensions (mm)

Part Number	A (mm)	B (mm)	C (mm)
1002427	31.2 ± 0.3	2.28 ± 0.3	3.9 ± 0.4

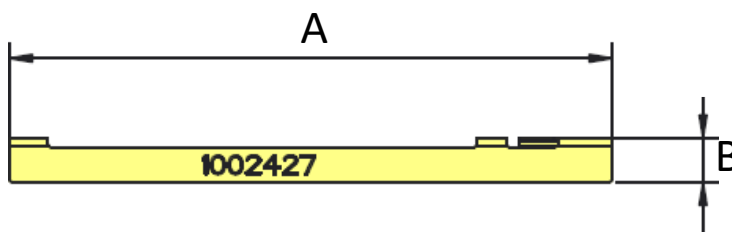
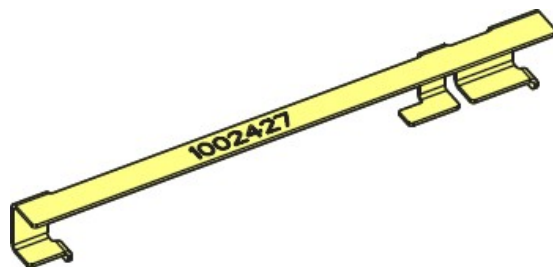

**Top View**

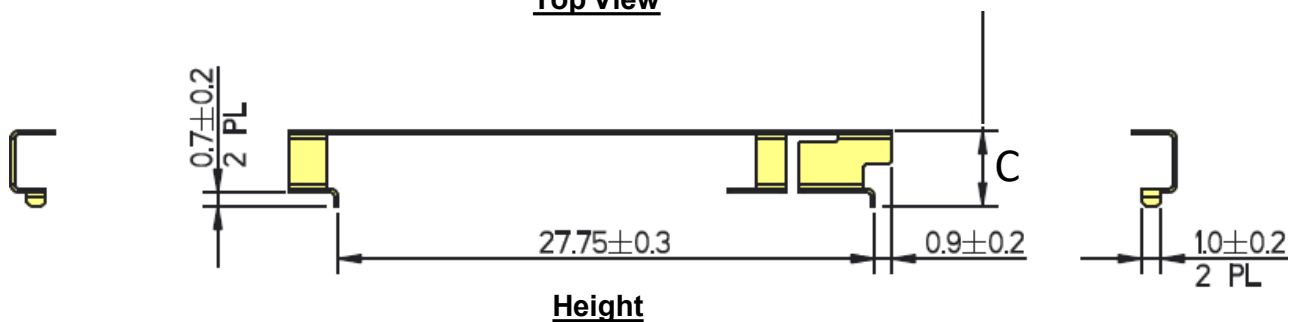

**Height**

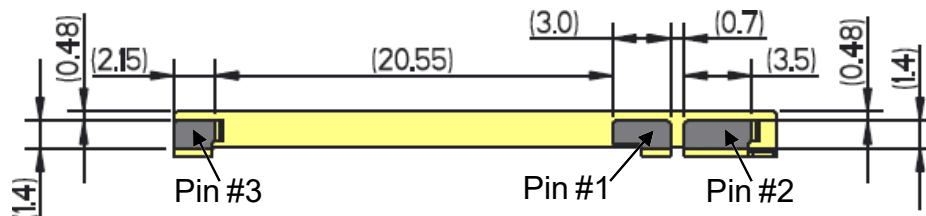

**Bottom View**

Pin#	Description
1	Feed
2	Ground
3	Dummy Pad

1002427 ISM or GPS layout performances (Single Band antenna)  
 KYOCERA AVX produces a wide variety of standard and custom antennas to meet user needs.

**VSWR and Efficiency Plots (ISM layout or GPS layout, Single Band antenna)**

Typical performance on 110 x 55 mm PCB

**Single Band antenna layout (ISM or GPS)**

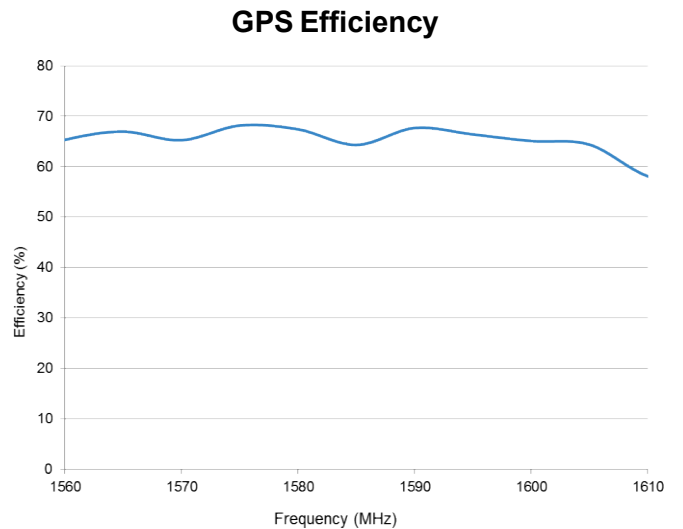
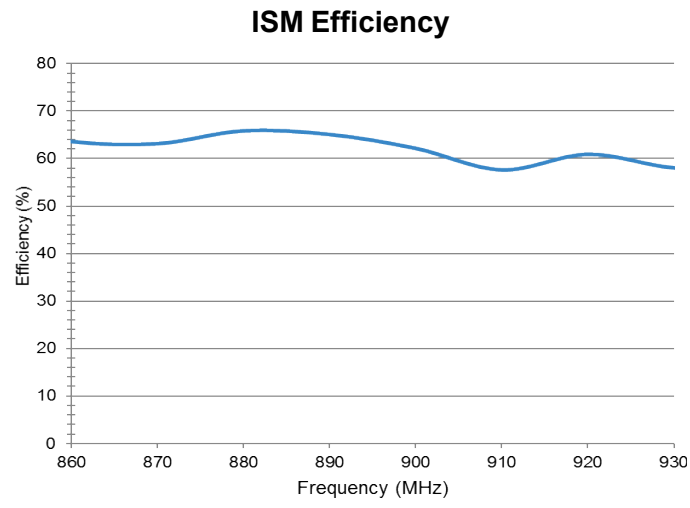
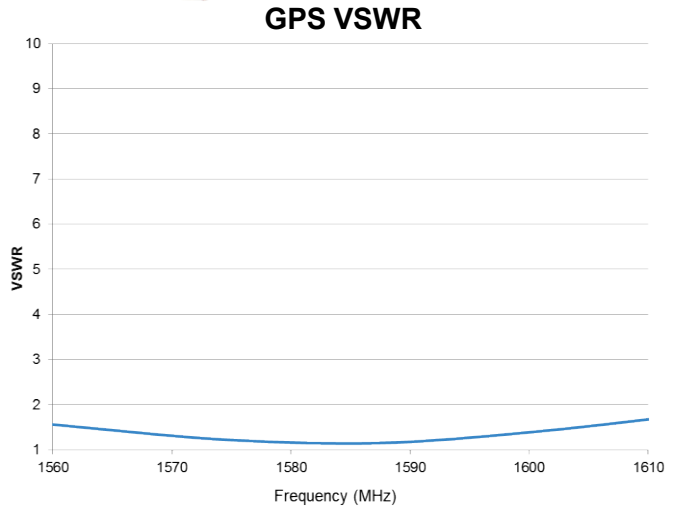
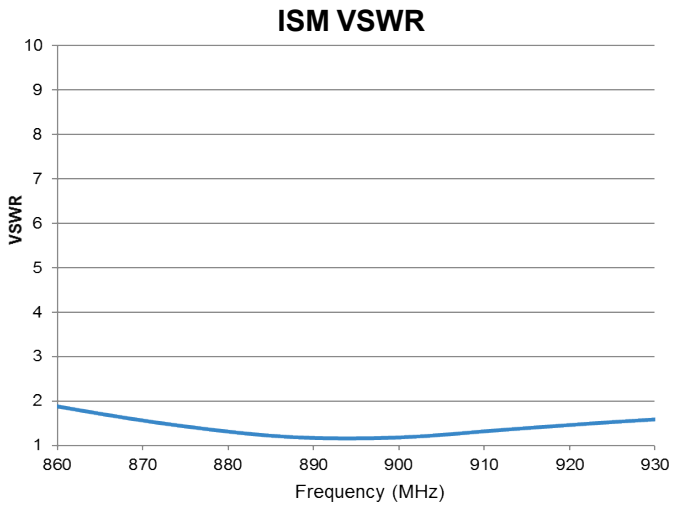
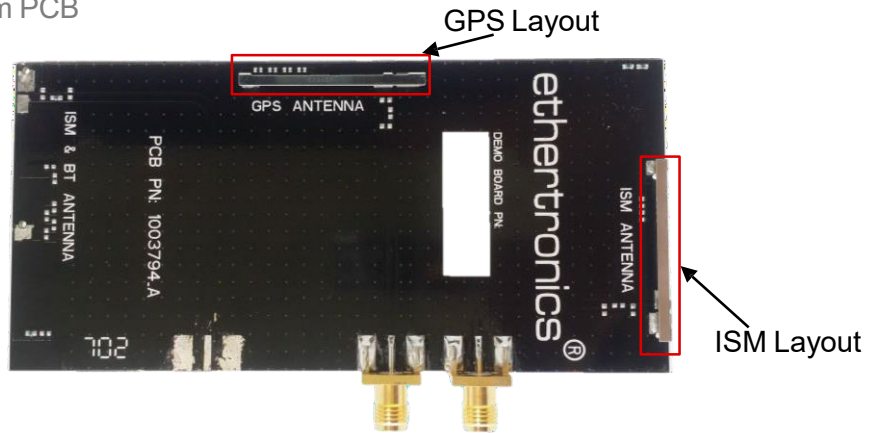

1002427 ISM or GPS layout performances (Single Band antenna)  
 KYOCERA AVX produces a wide variety of standard and custom antennas to meet user needs.

**Antenna Radiation Patterns (ISM layout or GPS layout, Single Band antenna)**

Typical performance on 110 x 55 mm PCB  
 Measured @ 870, 910, 1560, 1570, 1610 MHz

**Single Band antenna  
 (ISM Layout Orientation)**

**Single Band antenna  
 (GPS Layout Orientation)**

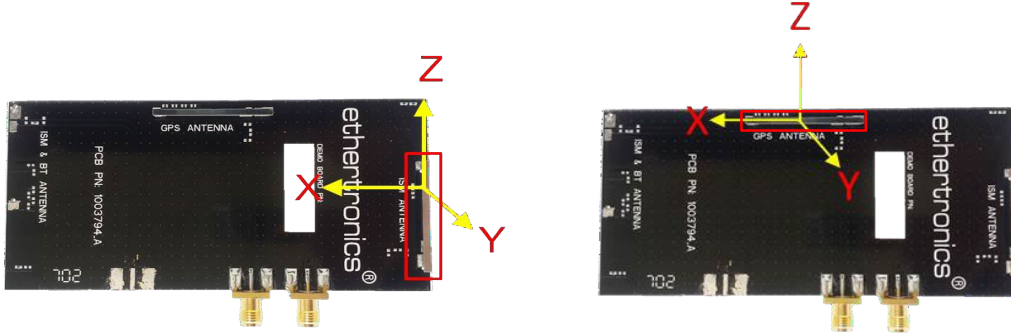

Measured at 870 / 910 MHz  
 (ISM)

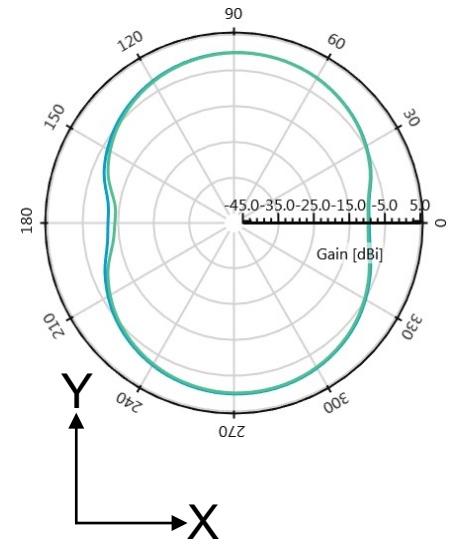
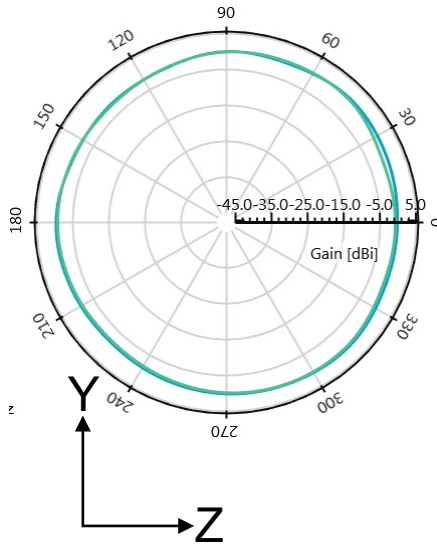
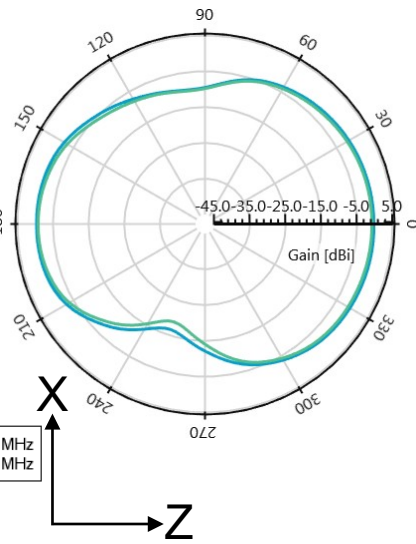
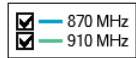

Measured at 1560, 1570, 1610 MHz  
 (GPS)

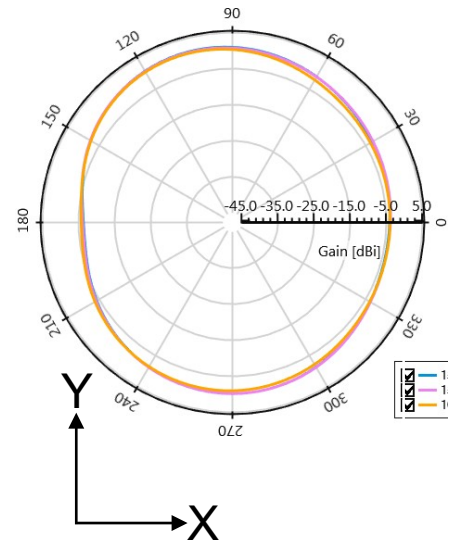
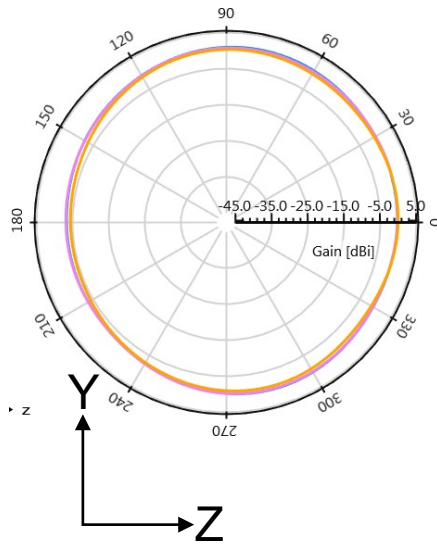
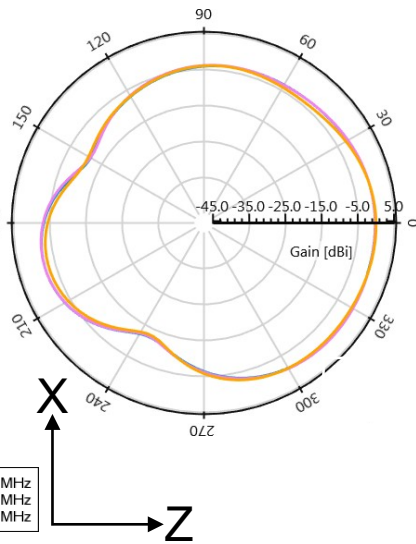
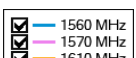

1002427 ISM & BT layout performances (Dual Band antenna)  
 KYOCERA AVX produces a wide variety of standard and custom antennas to meet user needs.

**VSWR and Efficiency Plots (ISM and BT layout, Dual Band antenna)**

Typical performance on 110 x 55 mm PCB

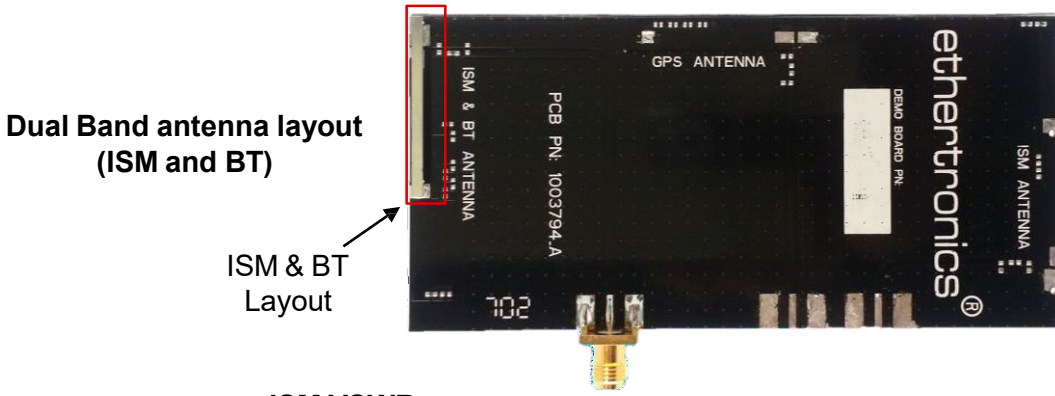

**ISM VSWR**

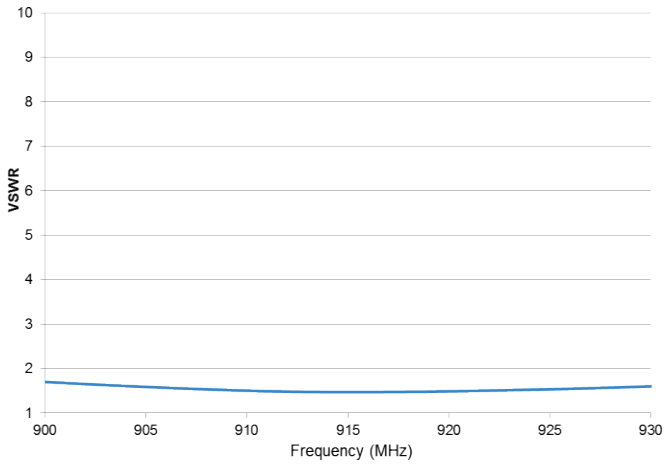

**BT VSWR**

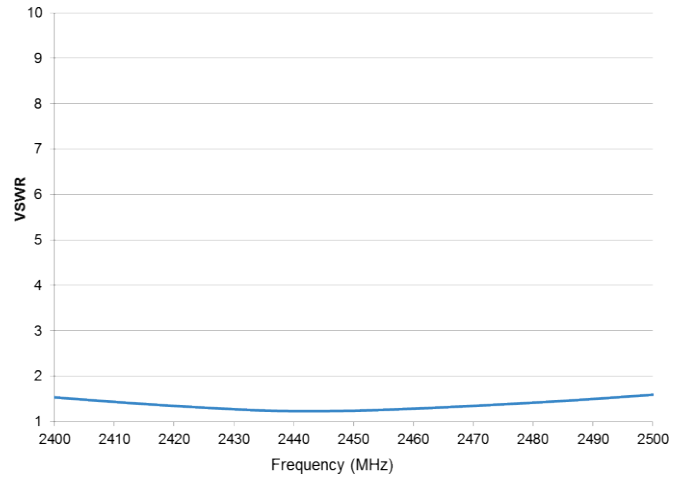

**ISM Efficiency**

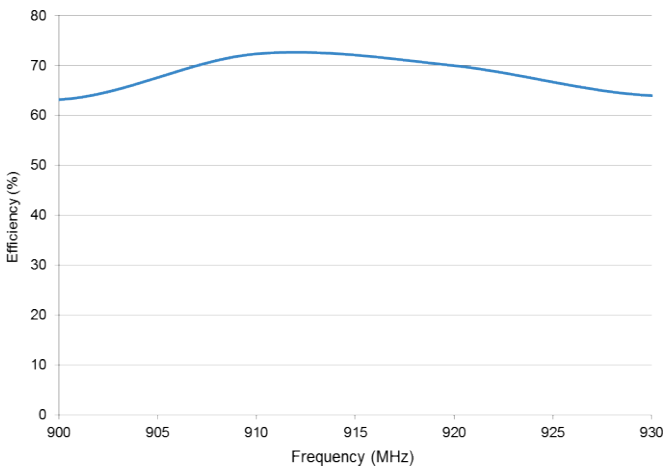

**BT Efficiency**

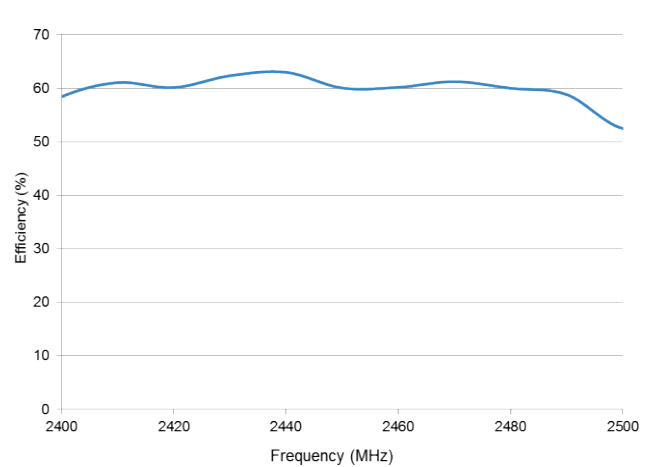

1002427 ISM & BT layout performances (Dual Band antenna)  
 KYOCERA AVX produces a wide variety of standard and custom antennas to meet user needs.

**Antenna Radiation Patterns (ISM & BT layout, Dual Band antenna)**

Typical performance on 110 x 55 mm PCB  
 Measured @ 910, 2450 MHz

**Dual Band antenna  
 (ISM & BT Layout Orientation)**

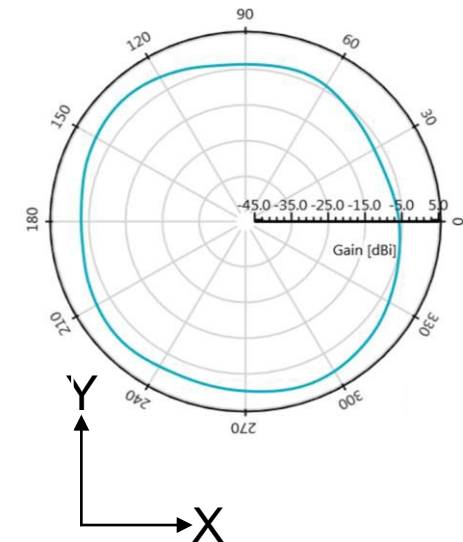
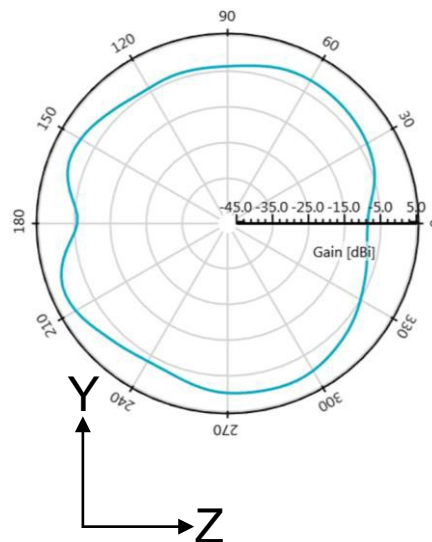
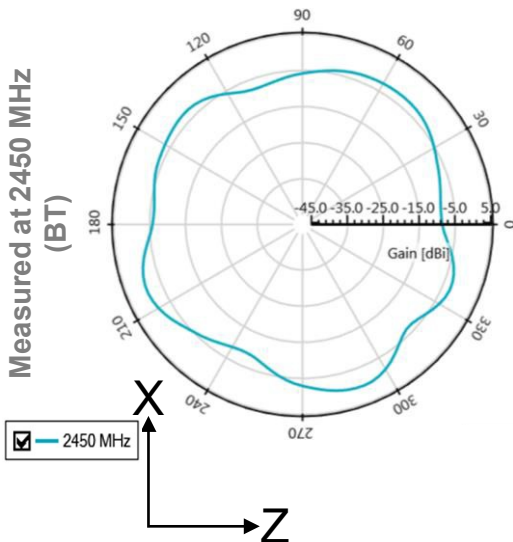
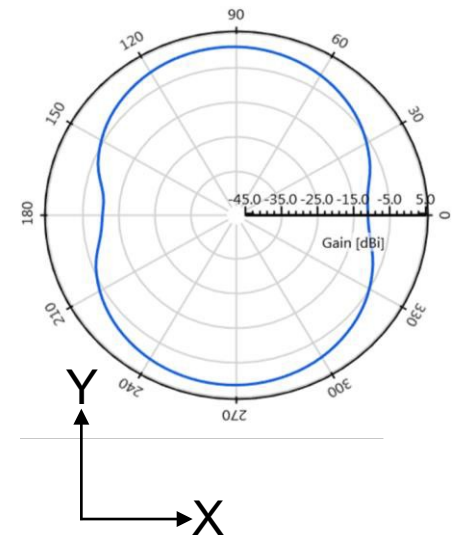
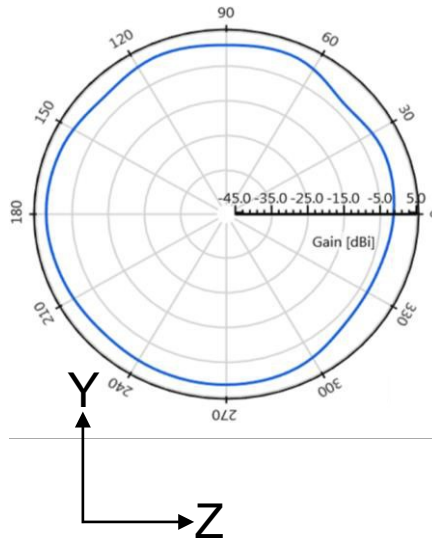
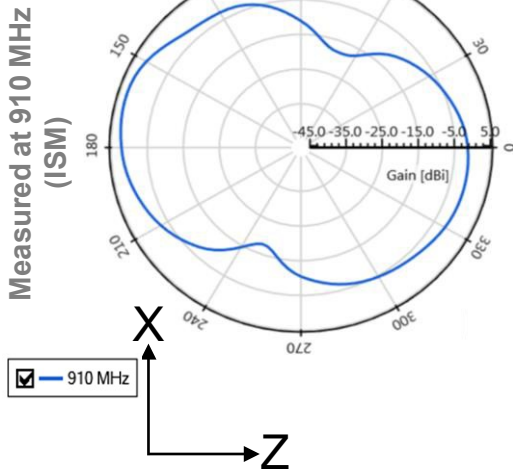
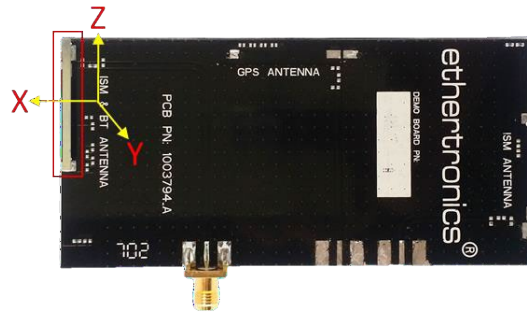

**ISM / GPS / BT Stamp Metal KYOCERA AVX Antenna Specifications (GPS Single Band antenna)**  
 KYOCERA AVX produces a wide variety of standard and custom antennas to meet user needs.

**Antenna Layout (GPS Layout ONLY)**

Typical layout dimensions (mm)

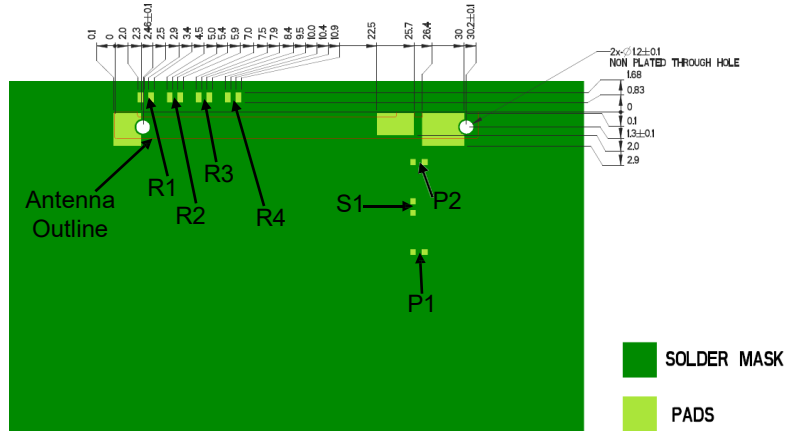
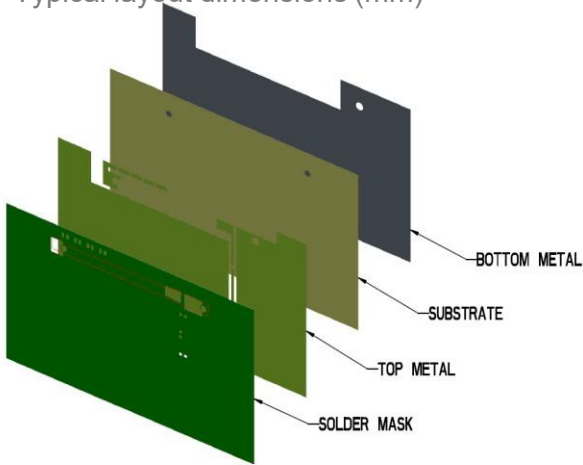

\* VIAS: Diam. 0.2mm, (no vias on transmission lines).  
 Via holes must be covered by solder mask

**Pin Descriptions**

Pin#	Description
1	Feed
2	Ground
3	Dummy Pad

**Matching & Tuning Component Values**

Component	Value	Tolerance
P1	DNI	N/A
S1	0Ω	N/A
P2	3.0pF	±0.05pF
R1 - R4	DNI	N/A

\*Actual matching values depend on customer design

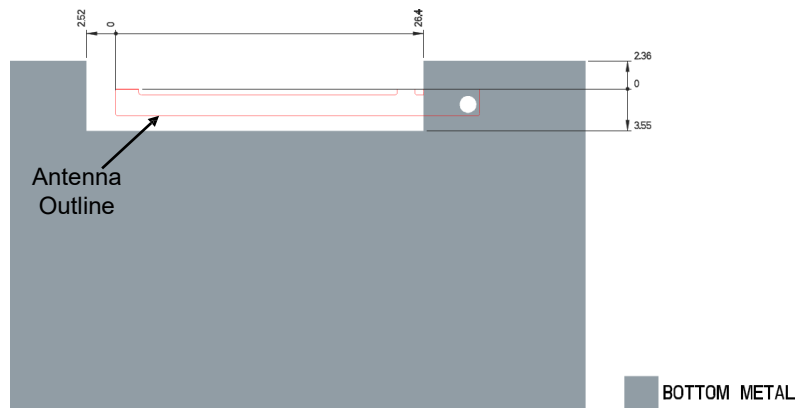
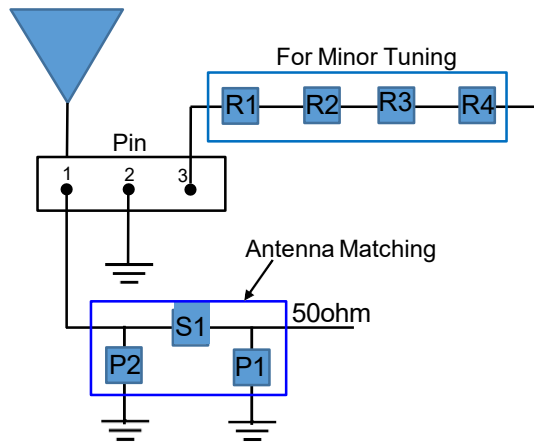
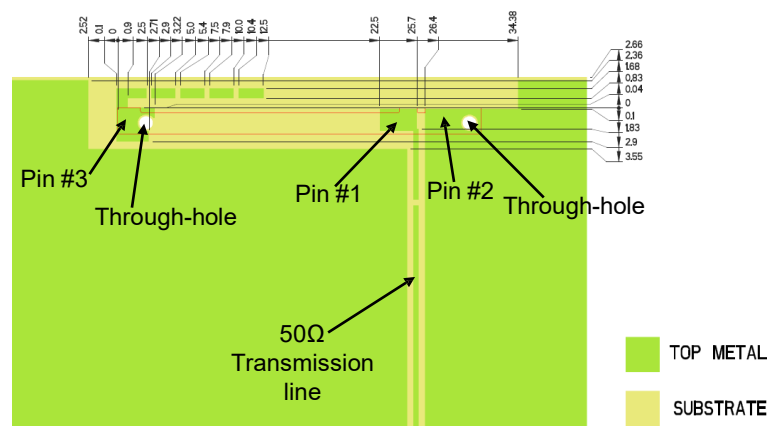

ISM / GPS / BT Stamp Metal KYOCERA AVX Antenna Specifications (ISM Single Band antenna)  
 KYOCERA AVX produces a wide variety of standard and custom antennas to meet user needs.

### Antenna Layout (ISM Layout ONLY)

Typical layout dimensions (mm)

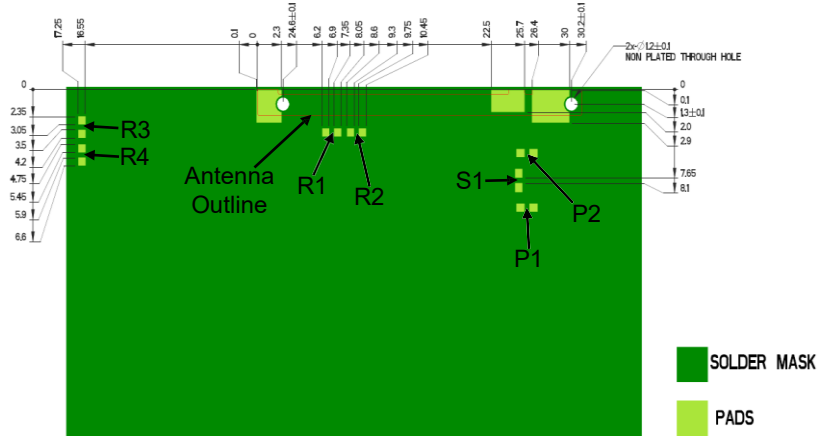
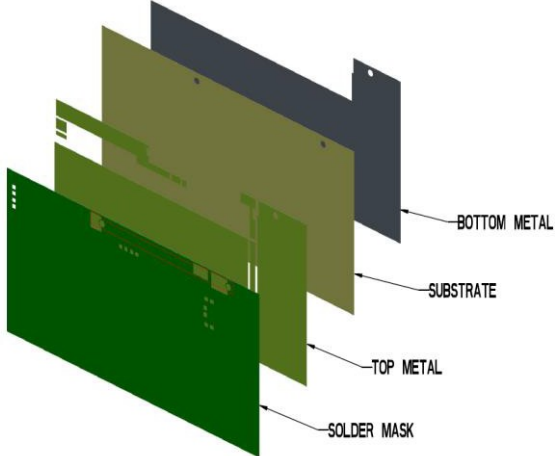

\* VIAS: Diam. 0.2mm, (no vias on transmission lines).  
 Via holes must be covered by solder mask

#### Pin Descriptions

Pin#	Description
1	Feed
2	Ground
3	Dummy Pad

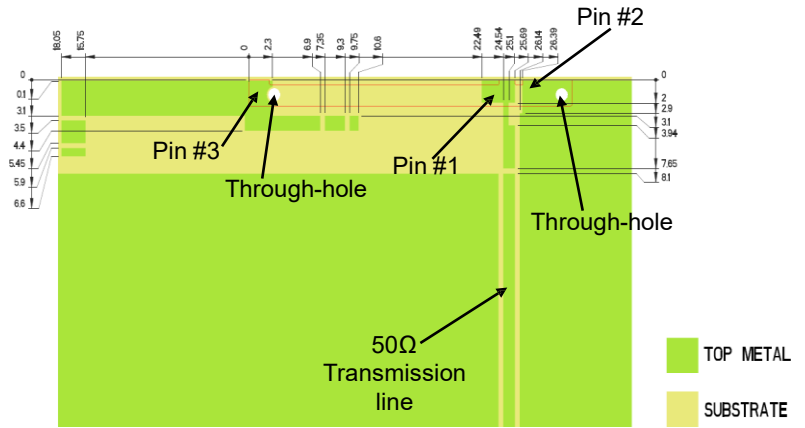

#### Matching & Tuning Component Values

Component	Value	Tolerance
P1	DNI	N/A
S1	5.6pF	±0.05pF
P2	1.8pF	±0.05pF
R1 - R4	0Ω	N/A

\*Actual matching values depend on customer design

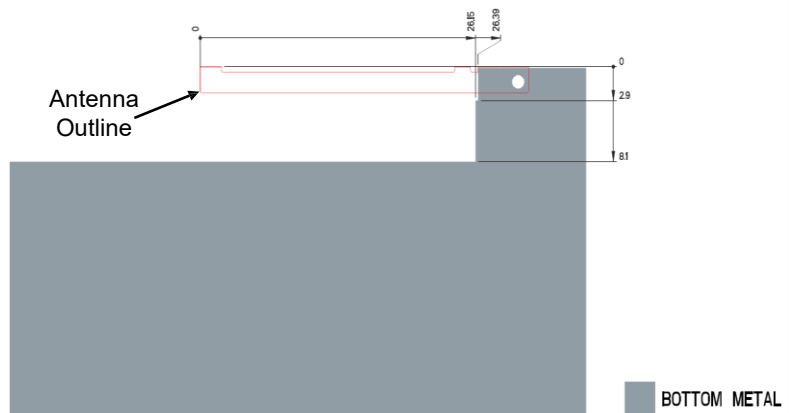
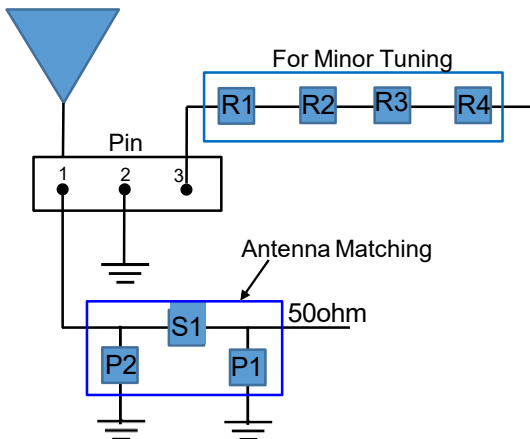



**ISM / GPS / BT Stamp Metal KYOCERA AVX Antenna Specifications (ISM & BT Dual Band antenna)**  
 KYOCERA AVX produces a wide variety of standard and custom antennas to meet user needs.

**Antenna Layout (ISM & BT Layout ONLY)**

Typical layout dimensions (mm)

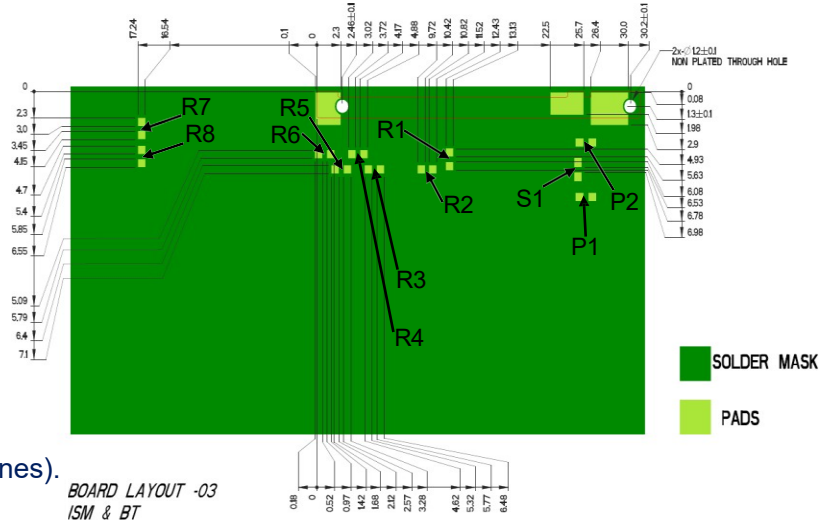
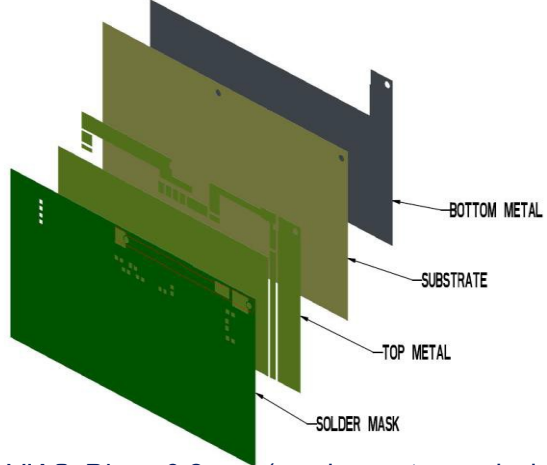

\* VIAS: Diam. 0.2mm, (no vias on transmission lines).  
 Via holes must be covered by solder mask

**Pin Descriptions**

Pin#	Description
1	Feed
2	Ground
3	Dummy Pad

**Matching & Tuning Component Values**

Component	Value	Tolerance
P1	DNI	N/A
S1	5.0pF	±0.05pF
P2	DNI	N/A
R1 – R8	DNI	N/A

\*Actual matching values depend on customer design

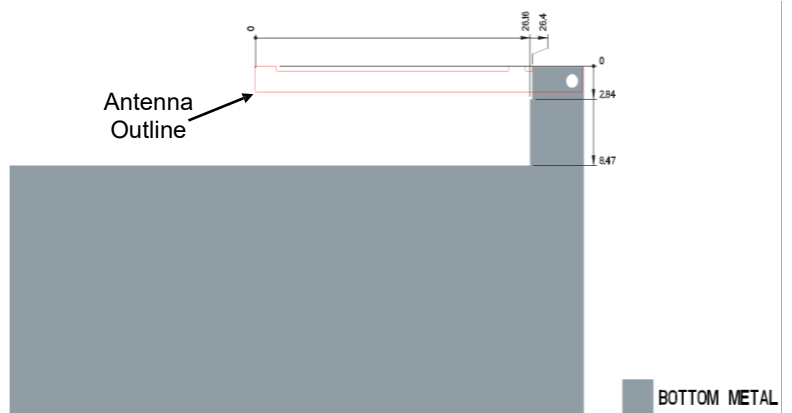
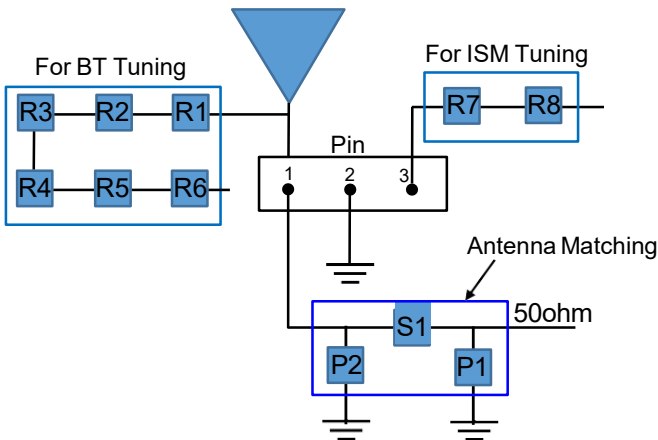
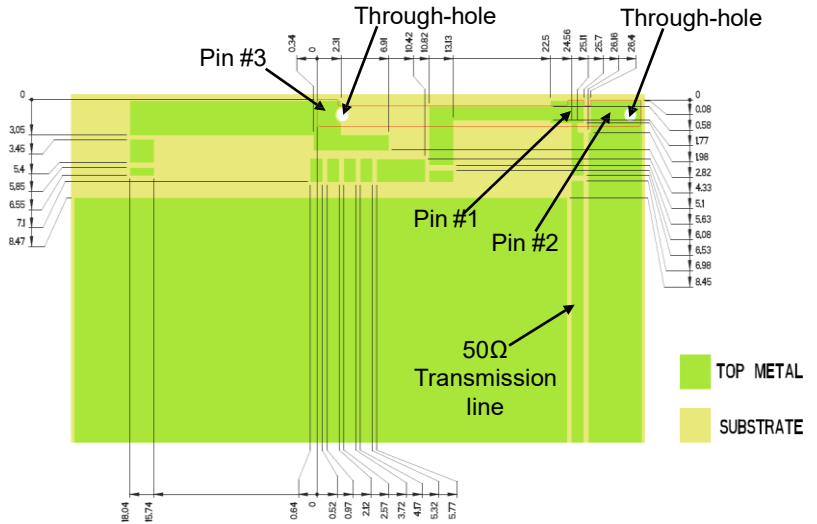

ISM / GPS / BT Stamp Metal KYOCERA AVX Antenna Specifications  
KYOCERA AVX produces a wide variety of standard and custom antennas to meet user needs.

**Antenna Layout cont. (through hole mounting)**

Typical layout dimensions (mm)

**PCB slots for through-hole mounting**

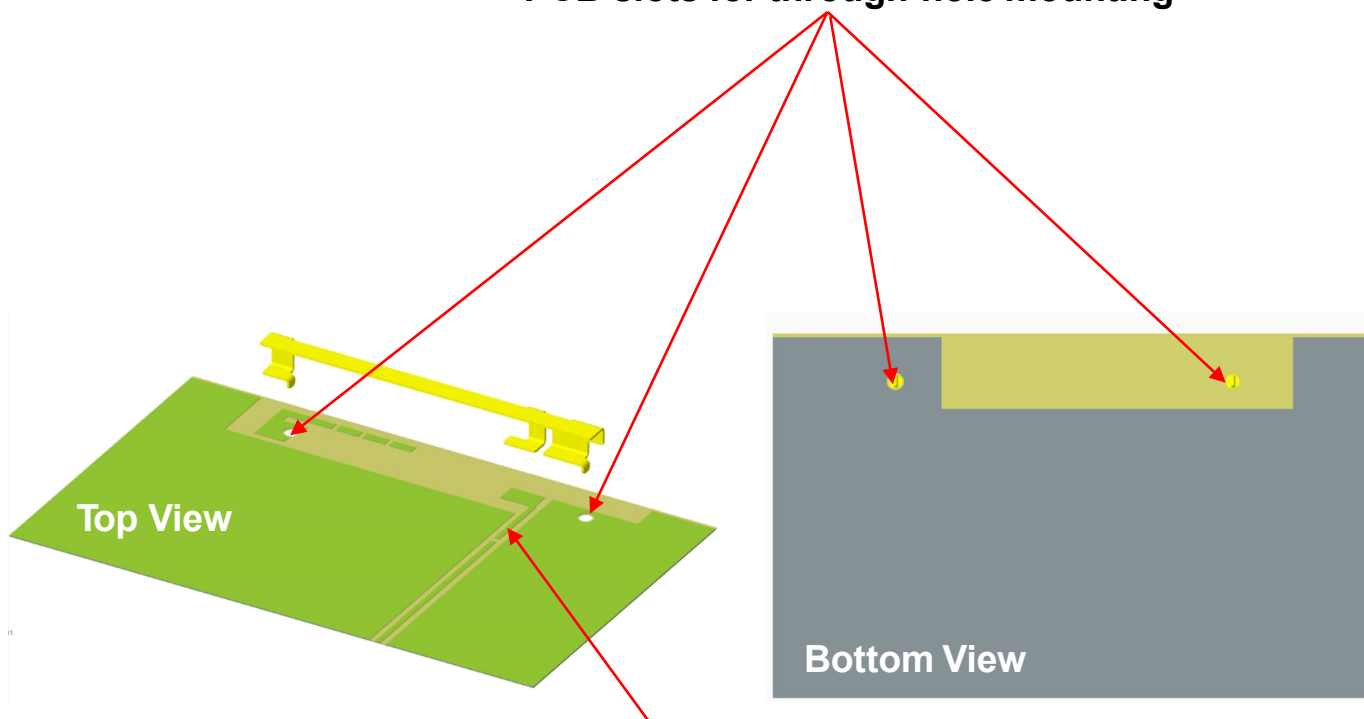

**A 50 ohm transmission line needs to be designed and connected at this location**

